

agrimac



DUMPERS HIDROSTÁTICOS, 1500 Kg.

HYDROSTATIC DUMPERS, 1500 Kg.

DUMPERS HYDROSTATIQUES, 1500 Kg.

DH-150 AH • DH-150 AHA • DH-150 AHG



 CARACTERÍSTICAS TÉCNICAS	 TECHNICAL FEATURES	 CARACTÉRISTIQUES TECHNIQUES	
MOTOR	Perkins, Diesel, 25 c.v., 3 cilindros, refrigerado por agua	MOTEUR	Perkins, Diesel, 25 c.v., 3 cylindres, refroidissement per eau
TRANSMISIÓN	Hidrostática 4 motores rueda Velocidad máx. en carga: 18 Km/h Tracción 4x2, OPCIÓN (4X4)	TRANSMISSION	Hydrostatical 4 wheel engines Max. Speed: 18 Km/h Traction: 4x2, OPTION (4X4)
DIRECCIÓN	Articulada	STEERING	Articulated
FRENOS	Hidrostáticos	BRAKES	Hydrostatic
RUEDAS	10.0/75-15.3 Ext: 3,41 m Int: 3 m	WHEELS	10.0/75-15.3 Ext: 3,41 m Int: 3 m
CIRCUITO HIDRÁULICO	Bomba de caudal variable Regulación automática Inversor eléctrico en joystick	HYDRAULIC CIRCUIT	Variable flow pump Automatic regulation Electrical joystick inverstor
CAPACIDADES	Capacidad de carga: 1.500 Kg	CAPACITIES	Load Capacity: 1.500 Kg
PESO	En vacío: 1.500 Kg	WEIGHT	Empty: 1.500 Kg
EQUIPAMIENTO DE SERIE:	Asiento de suspensión con apoya brazos y regulable, Girofaro, Espejo retrovisor Arco de protección ROPS, abatible, según UNE-EN 13510 Avisador acústico marcha atrás.	SERIE EQUIPMENT	Suspension seat with arm lean and regulable Headlight turning Rear view glass Protection arc ROPS, folding, according UNE-EN 13510 Raer speed acustic adviser
EQUIPAMIENTO OPCIONAL:	Instalación eléctrica de luces	OPTIONAL EQUIPMENT:	Lighting electrical instalation
MODELOS	DH-150 AH: Descarga Frontal DH-150 AHA: Descarga en altura hasta 1,75 m DH-150 AHG: Descarga giratoria 180°	MODELS:	DH-150 AH: Front discharge DH-150 AHA: Heigh discharge up to 1,75 m DH-150 AHG: Lateral discharge: 180°
		MODÈLES:	DH-150 AH: Décharge frontal DH-150 AHA: Décharge en hauteur 1,75 m DH-150 AHG: Décharge giratoire 180°

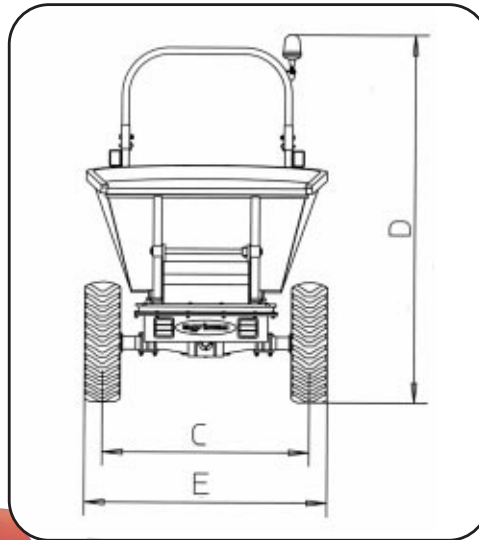
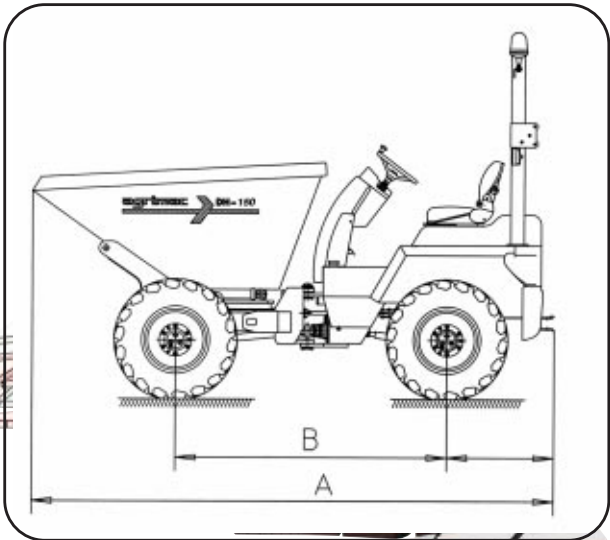

DIMENSIONES DIMENSIONS DIMENSIONS	
	DH-150
A	3.450
B	1.650
C	1.280
D	2.525
E	1.500

agrimac
 AGRIA HISPANIA, S.A.
 Telf.: +34 94 630 00 55 • Fax: +34 94 630 01 34 • Apartado 26
 E-mail (España): construccion@agria.net
 E-mail (Export): export@agria.net
 http://www.agria.net
 48340 AMOREBIETA (Vizcaya) ESPAÑA

DISTRIBUIDOR: / DEALER: / DISTRIBUTEUR: